

- 1. 1 -

Physics 121

Motion in 1 dimension

Consider the motion you just observed;
which motion diagram best represents
what you saw?

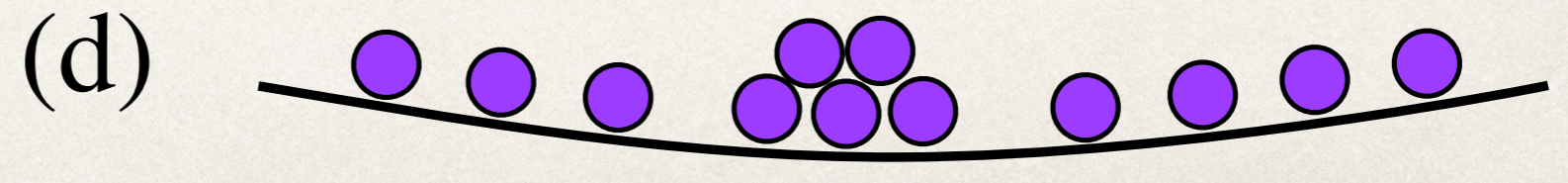
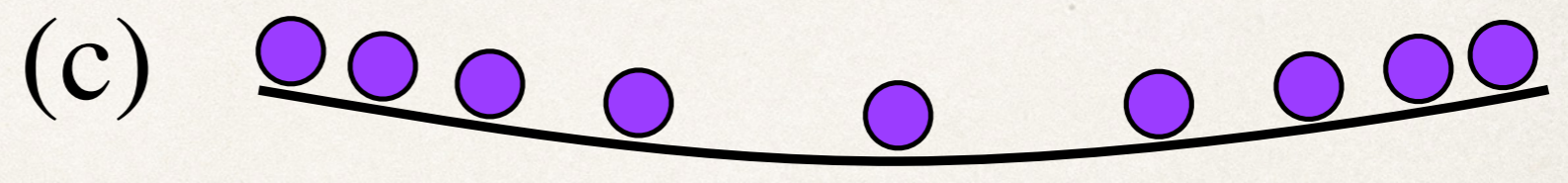
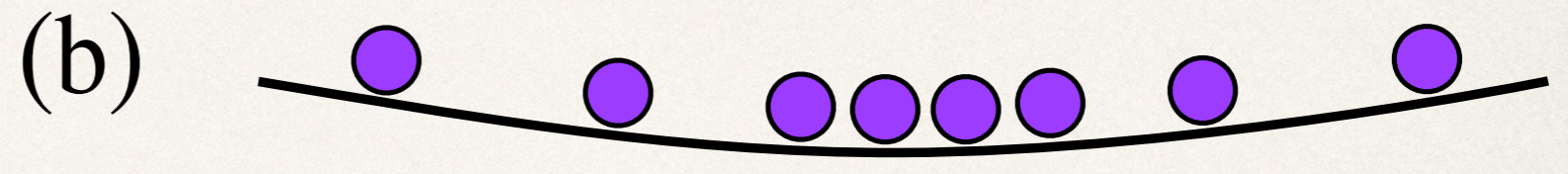
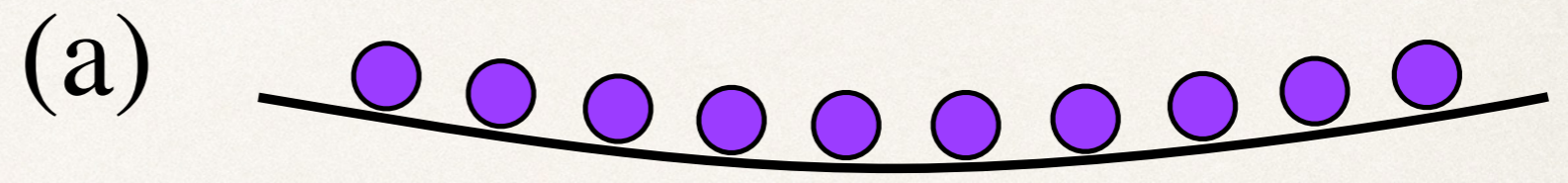

Which object, A or B,
has the larger *velocity*?

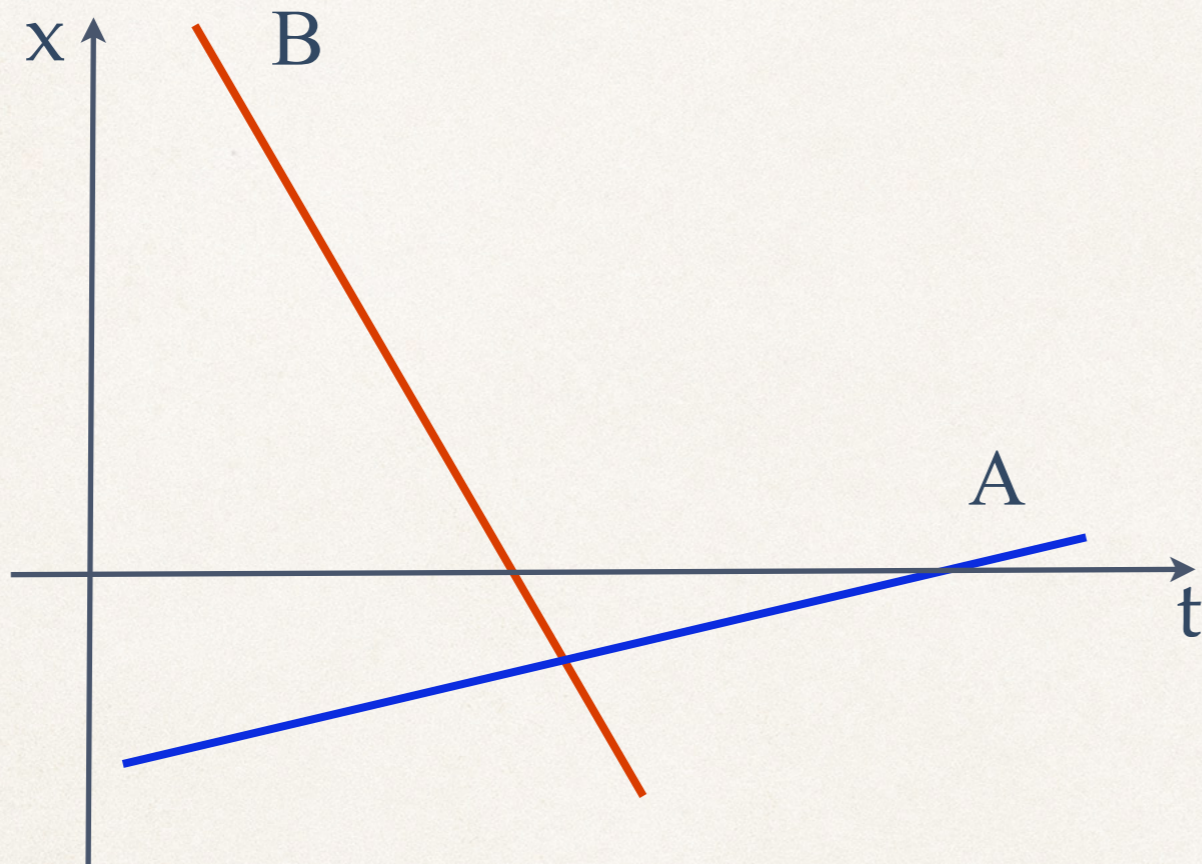

Rank order the *speeds* at times 1, 2, and 3 from the slowest to the fastest:

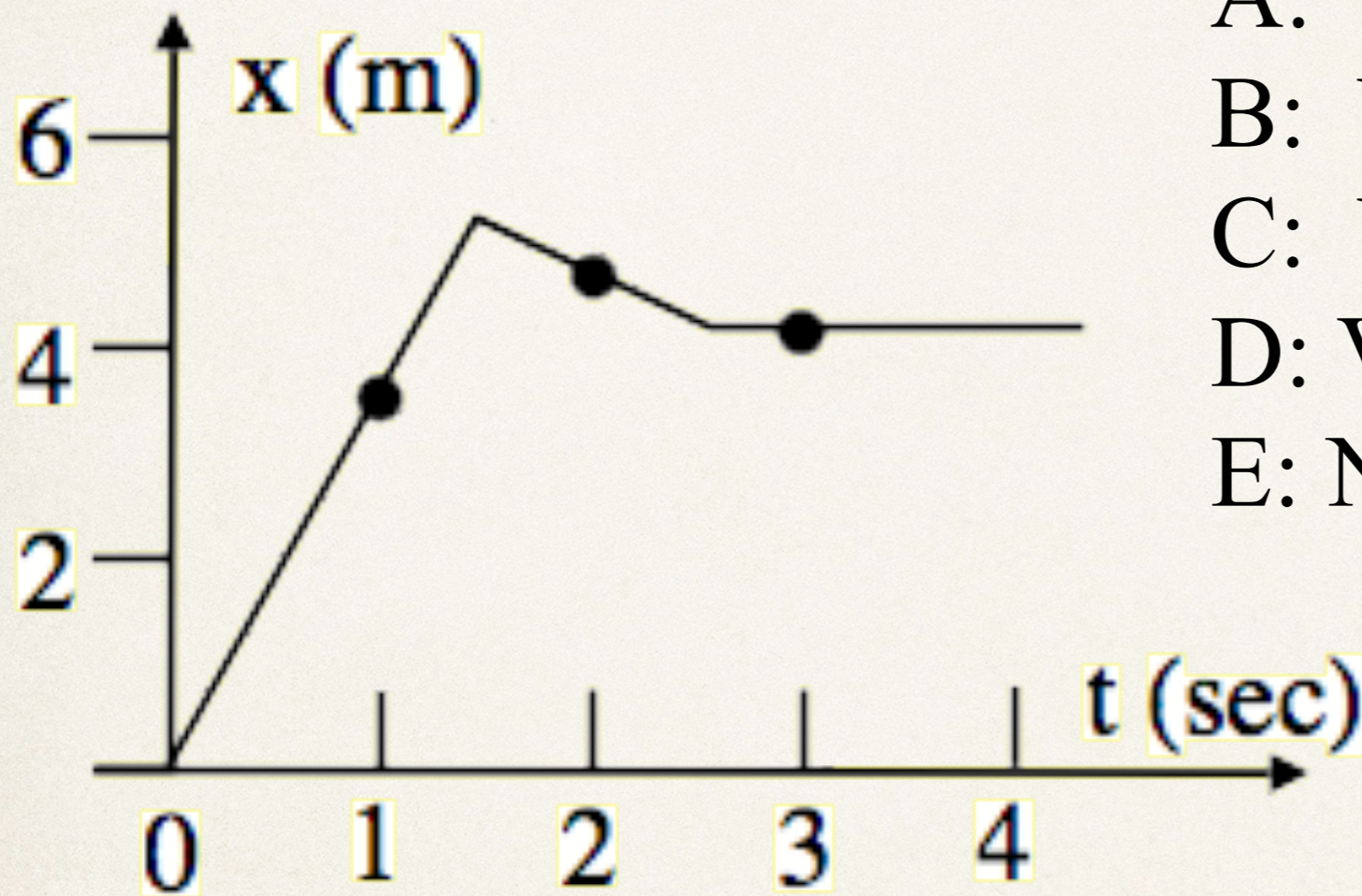

A: $V1 < V2 < V3$

B: $V2 < V1 < V3$

C: $V3 < V1 < V2$

D: $V3 < V2 < V1$

E: None of these/ not sure

The graph shows position as a function of time for two trains running on parallel tracks.

Which is true:

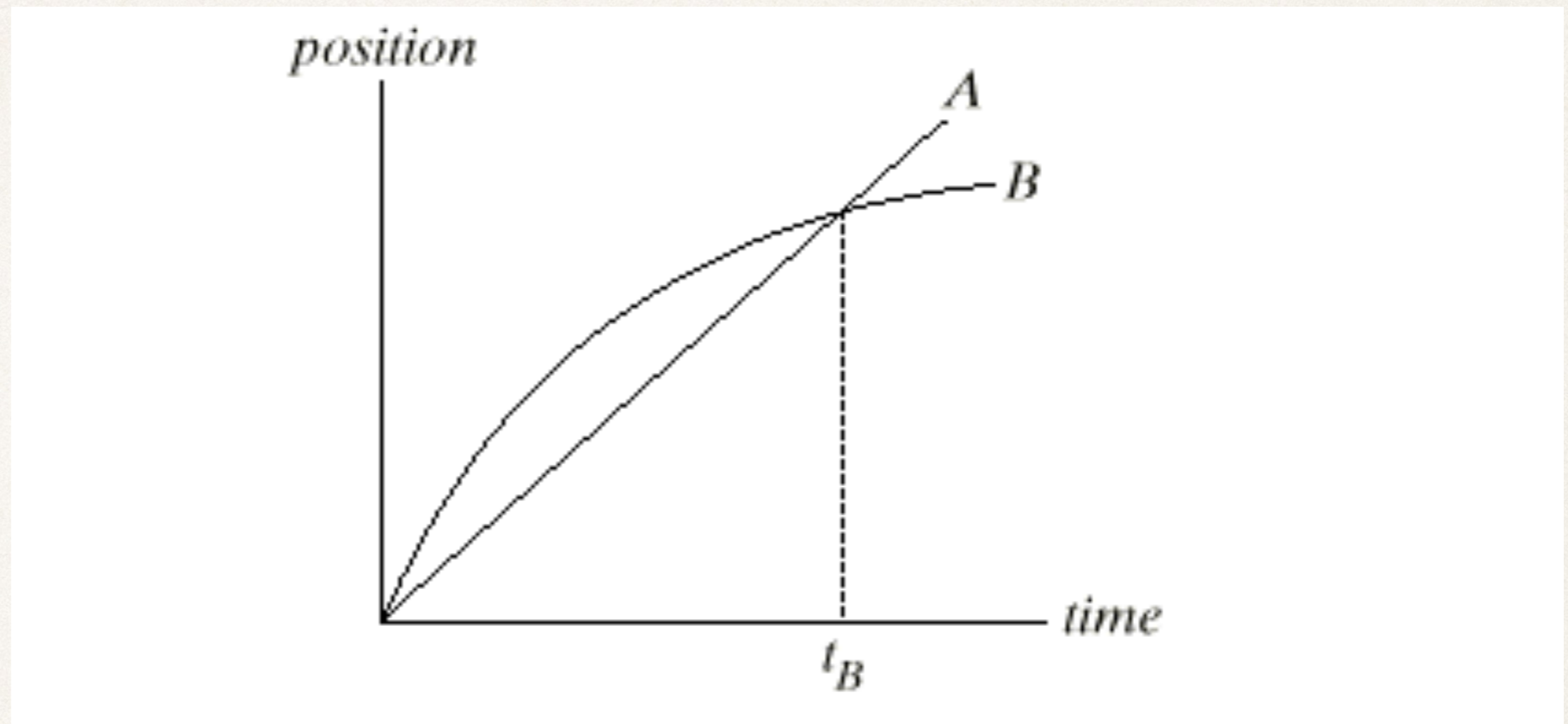

- A: At time t_B , both trains have the same velocity.
- B: Both trains speed up all the time.
- C: Both trains have the same velocity at some time before t_B .
- D: Somewhere on the graph, both trains have the same acceleration.

-1.2-

Motion in 1 dimension

If x is in meters, A is in m/s, and B is in m/s^2 , which of the following is dimensionally correct?

a) $x = At - Bt^3$

b) $x = \frac{A}{t} - Bt$

c) $x = Bt^2 - At$

d) $x = At^2 + Bt$

A marathon runner runs at a steady 15 km/hr. When the runner is 7.5 km from the finish, a bird begins flying from the runner to the finish at 30 km/hr. When the bird reaches the finish line, it turns around and flies back to the runner, and then turns around again, repeating the back-and-forth trips until the runner reaches the finish line. How many kilometers does the bird travel?

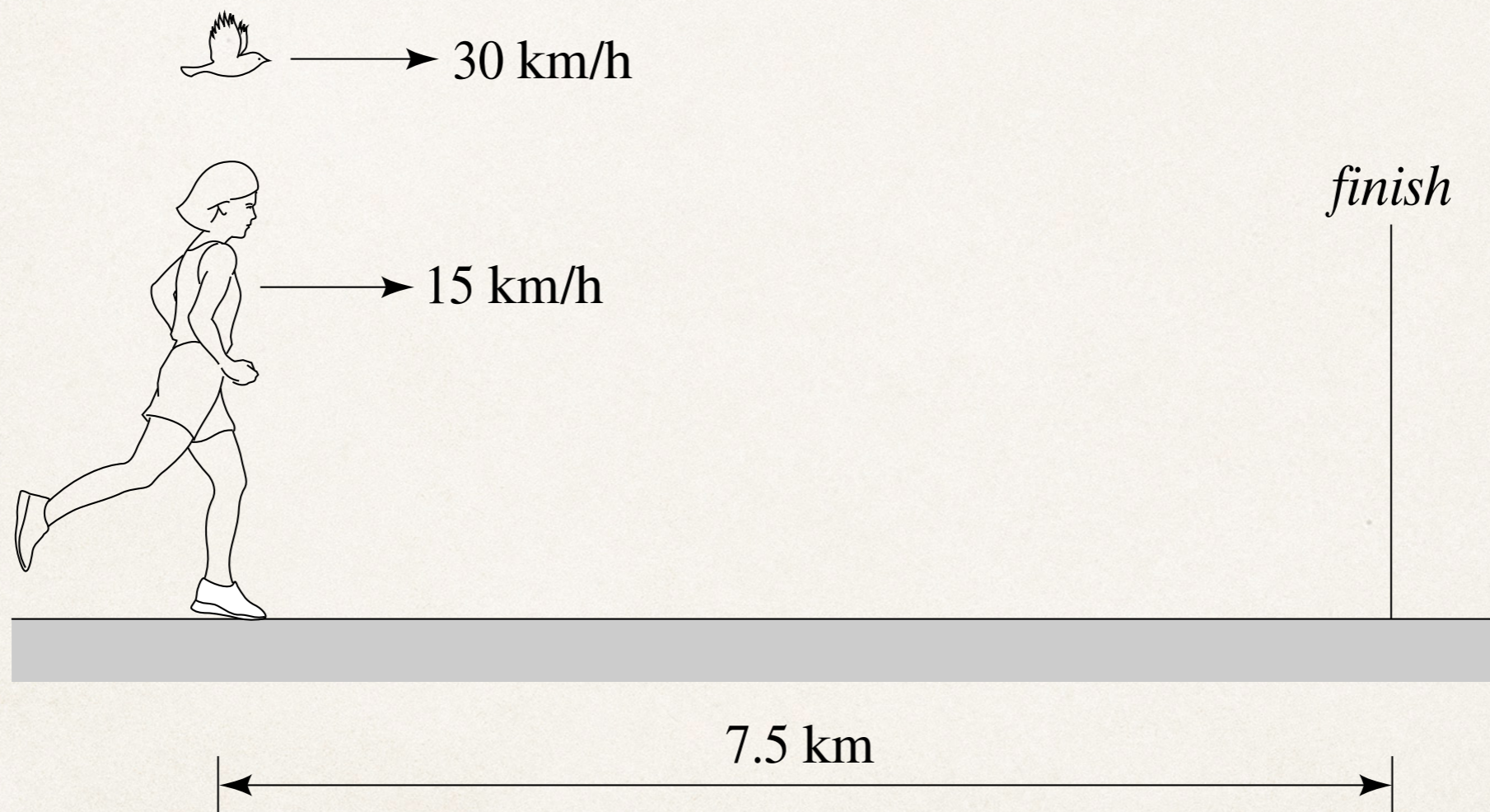

- a) 10 km
- b) 15 km
- c) 20 km
- d) 30 km

A ball is thrown straight upward. At the top of its trajectory, its acceleration is:

- A: zero
- B: straight up
- C: straight down
- D: depends on the mass of the ball

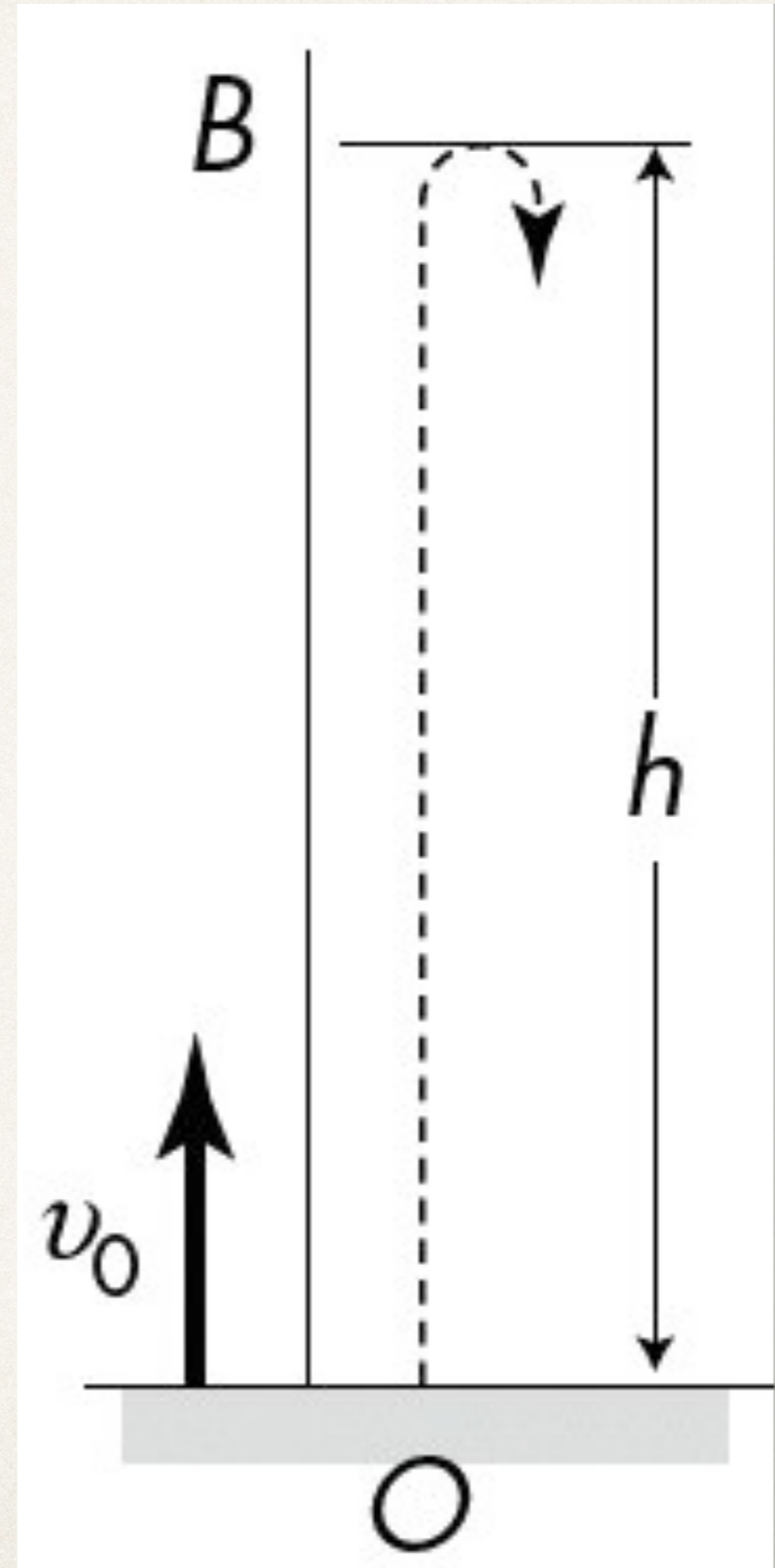

A glider on a tilted air track is given a brief push uphill. The glider coasts up to near the top end, stops, and then slides back down. When the glider is at the highest point of its path, its acceleration is..

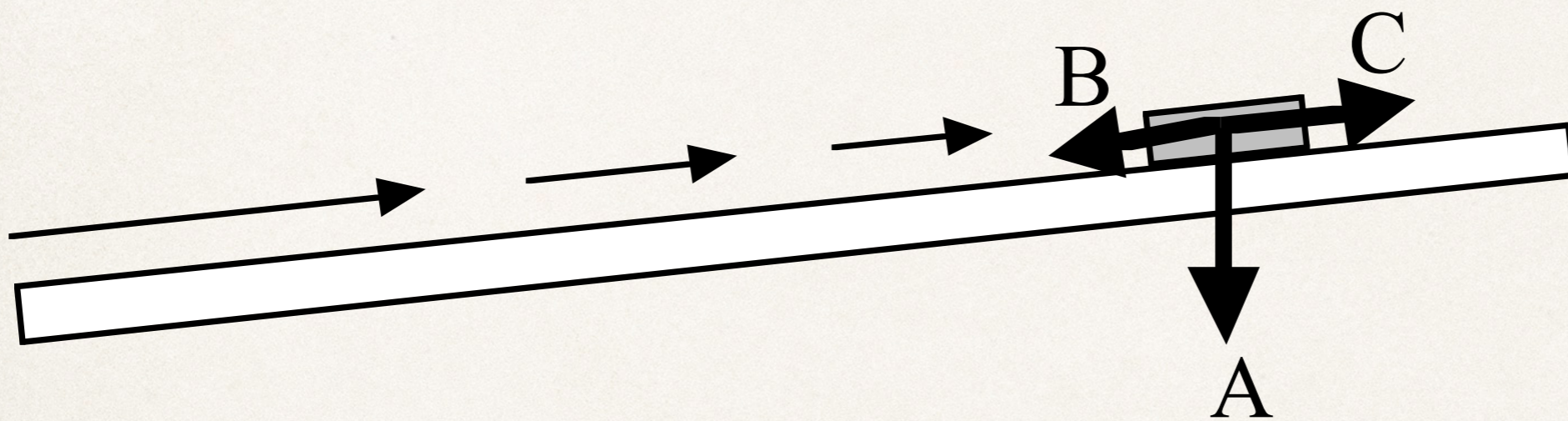

A: straight down

B: downward along the track

C: upward along the track

D: no direction, the acceleration is zero.

If you drop an object in the absence of air resistance, it accelerates downward at 9.8 m/s^2 . If instead you throw it downward, its downward acceleration after release is

1. less than 9.8 m/s^2 .
2. 9.8 m/s^2 .
3. more than 9.8 m/s^2 .

A person standing at the edge of a cliff throws one ball straight up and another ball straight down at the same initial speed. Neglecting air resistance, the ball to hit the ground below the cliff with the greater speed is the one initially thrown

1. upward.
2. downward.
3. neither—they both hit at the same speed.

- 3 -

Vectors

Several displacement vectors are shown below.
Which of the following has the least *magnitude*:

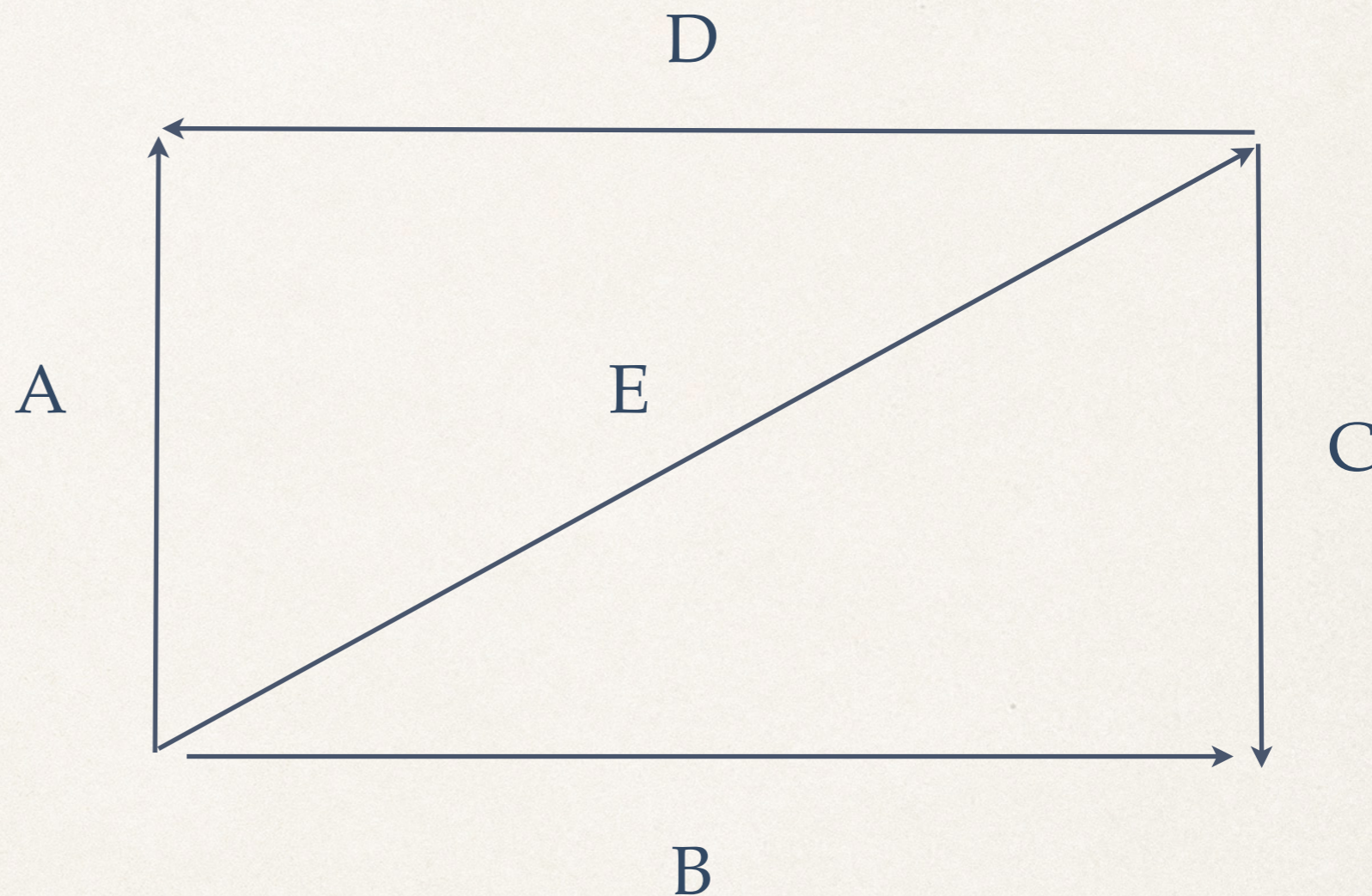

- a) $A+B-D$
- b) $C+D-B$
- c) $A+B-D-C$
- d) $C+D-E$
- e) $A+B-E$

What is the angle between the vectors A & B if

$$\vec{A} = 4\hat{i} - 6\hat{j}$$

$$\vec{B} = 6\hat{i} + 4\hat{j} + 23\hat{k}$$

- a) 0°
- b) 10°
- c) 45°
- d) 90°
- e) 120°

If the angle between the vectors A & B below is 180° , which of the following is **not** a possible value of the x-component B_x ?

$$\vec{A} = 4\hat{i} - 6\hat{j}$$

$$\vec{B} = B_x\hat{i} + 4\hat{j} + 23\hat{k}$$

- a) 2.25 b) 3.00 c) 4.60 d) 5.75
e) 8.00

What is the direction of $\vec{J} \times \vec{K}$?

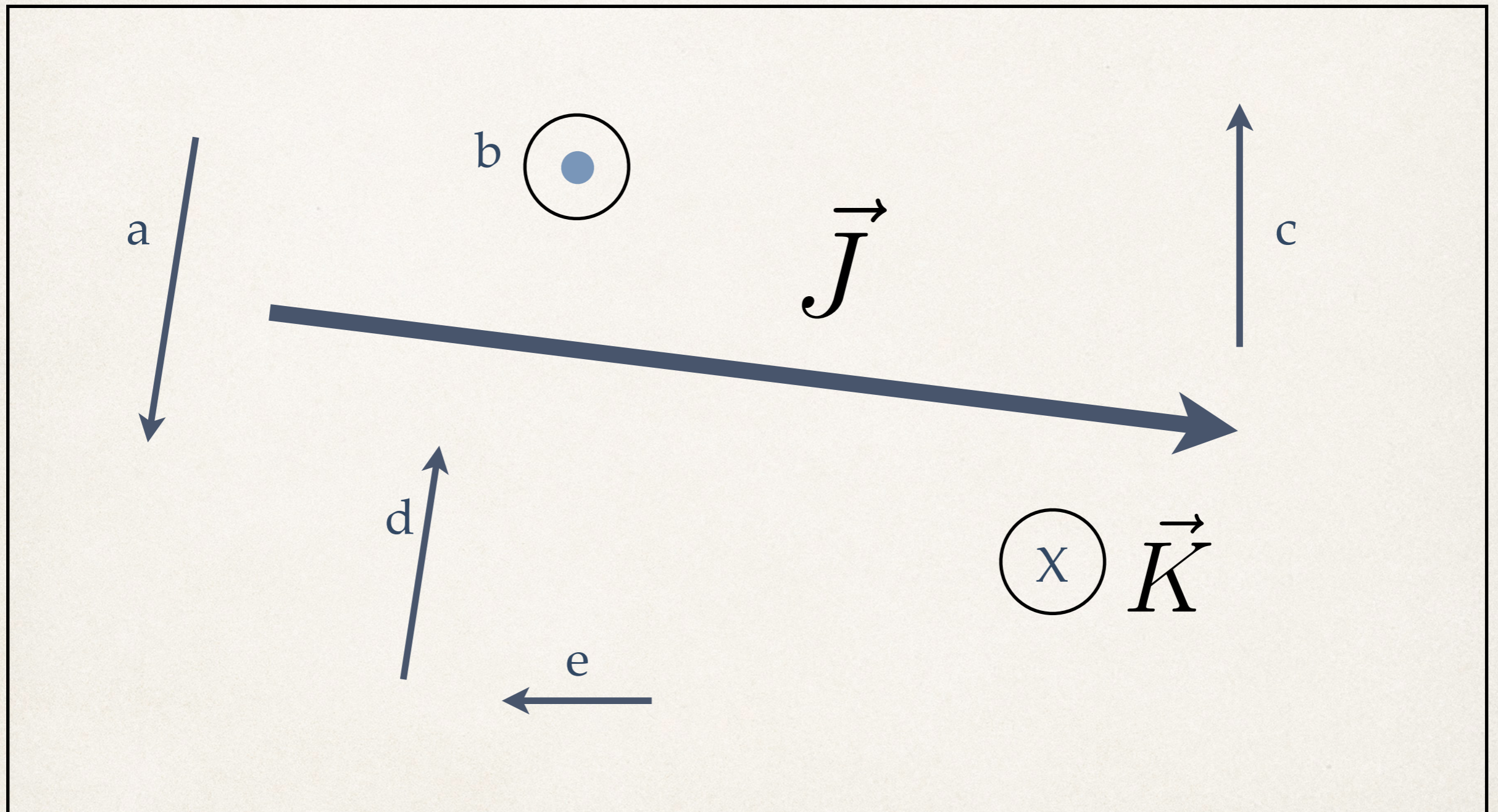

-4-

A battleship simultaneously fires two shells at enemy ships. If the shells follow the parabolic trajectories shown, which ship gets hit first?

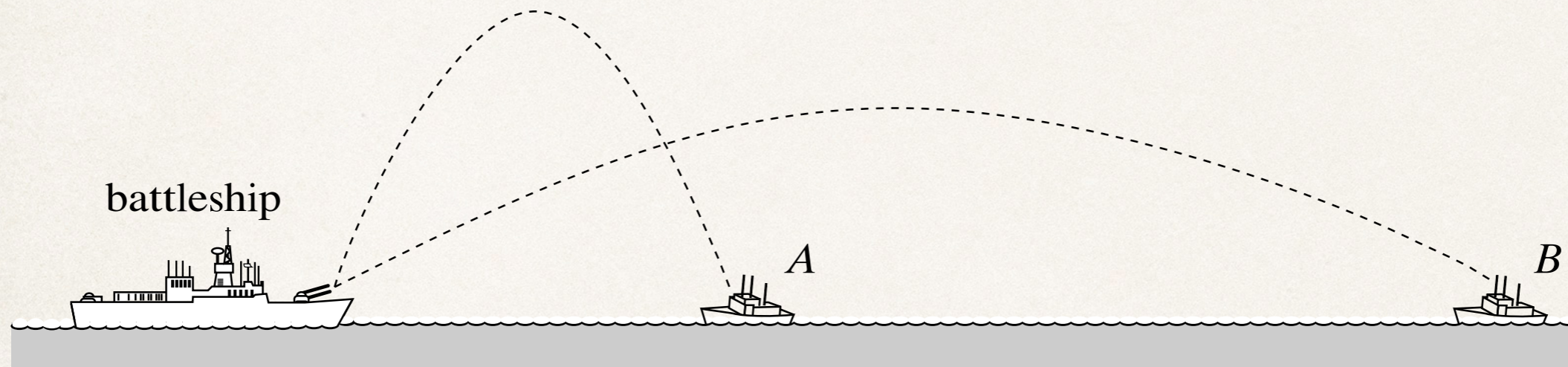

1. *A*
2. both at the same time
3. *B*
4. need more information

Suppose that you travel in a horizontal circle at constant speed v as shown below (looking down from above). What direction is your acceleration at the instant shown?

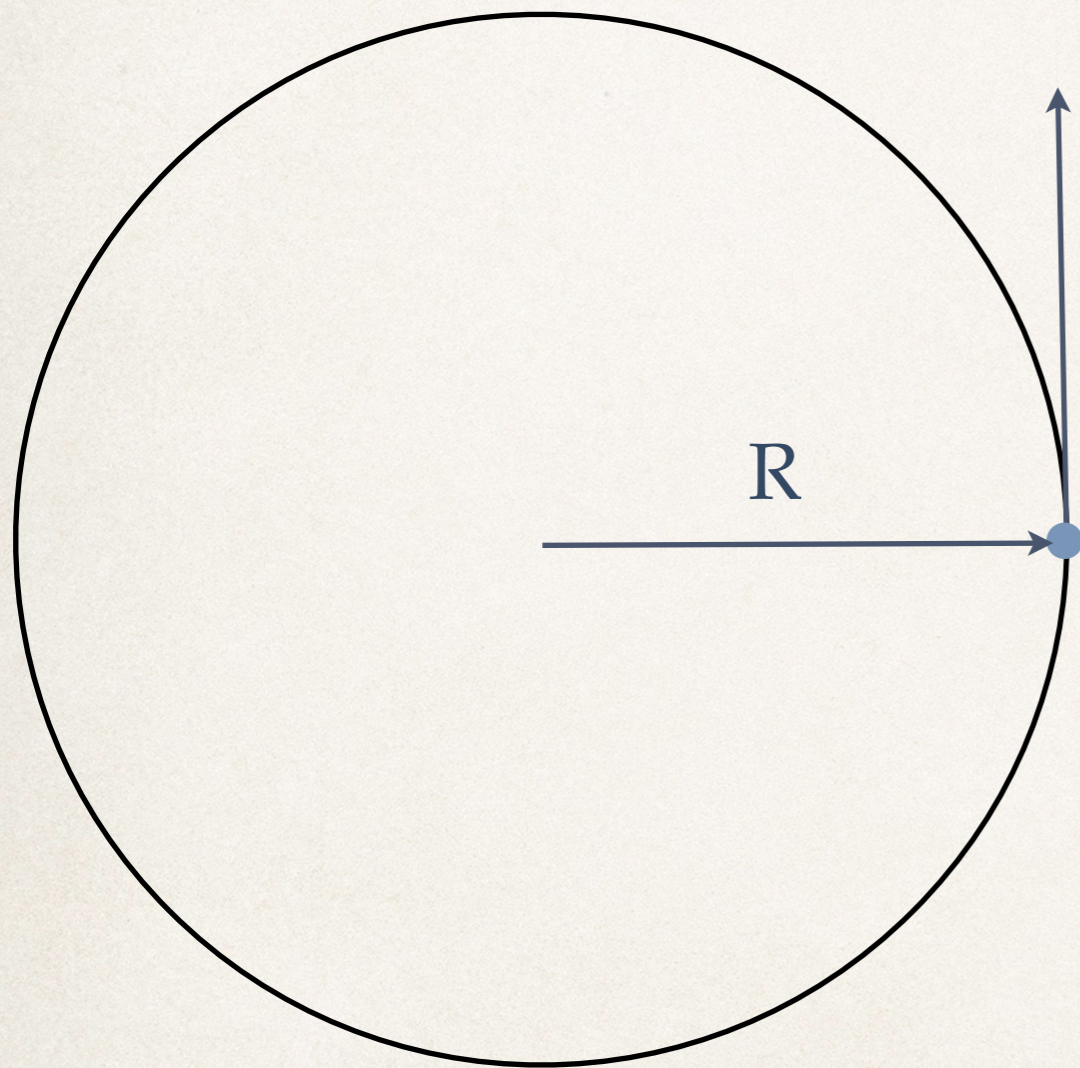

- a) to the left
- b) up
- c) to the right
- d) down
- e) none of these

Suppose that you are sitting on a rotating merry-go-round which is turning at an angular velocity of 10 radians/sec. If you are at a distance of 2.0 meters from the axis of rotation, what is your centripetal acceleration in units of m/s^2 ?

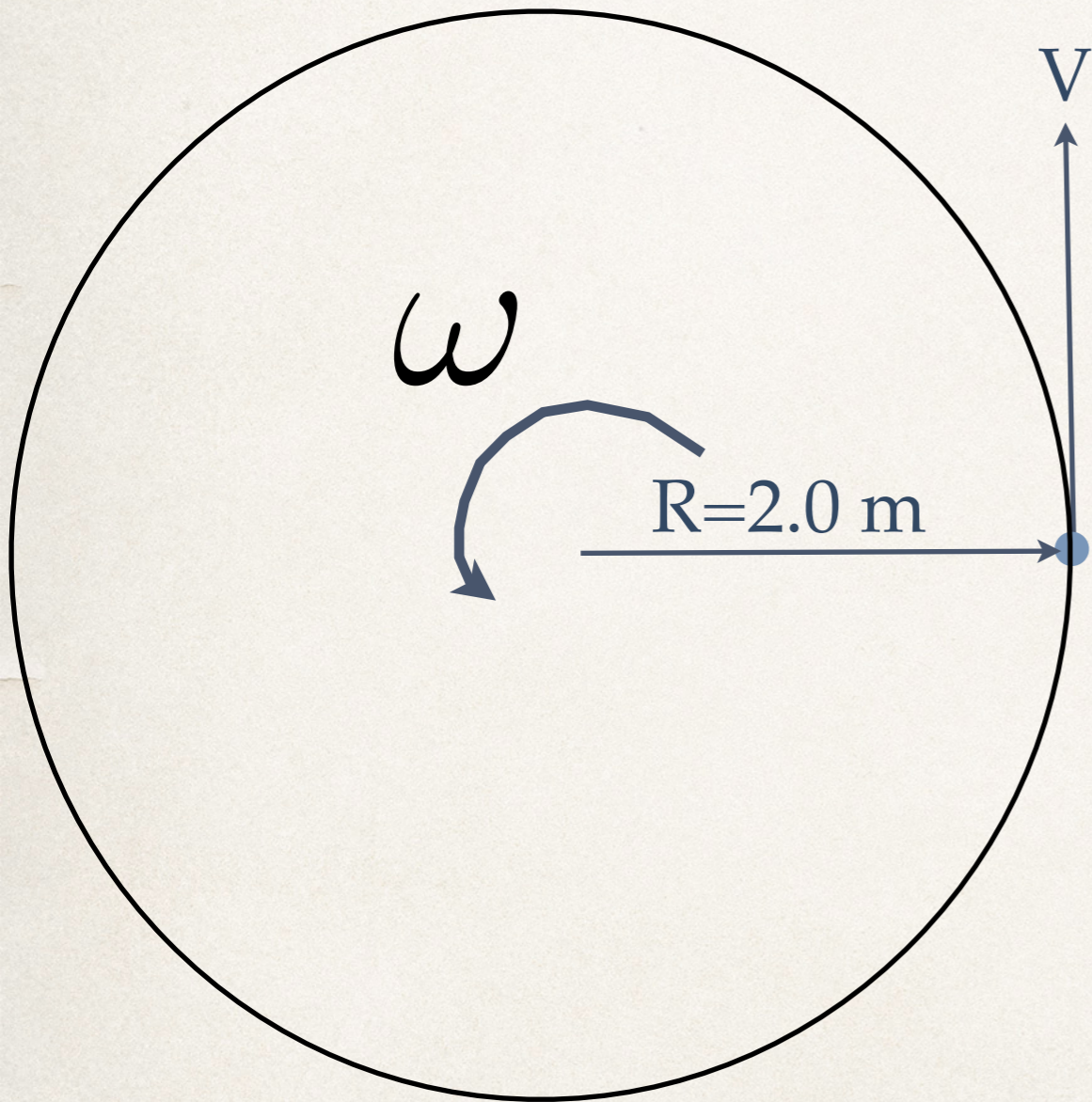

a) 200

b) 100

c) 50

d) 20

e) 5

Suppose that you are sitting on a rotating merry-go-round which is turning at a constant angular velocity of 10 radians/sec. If you are at a distance of 2.0 meters from the axis of rotation, and then you decrease your distance from the axis of rotation to 1.0 m, what happens to your centripetal acceleration?

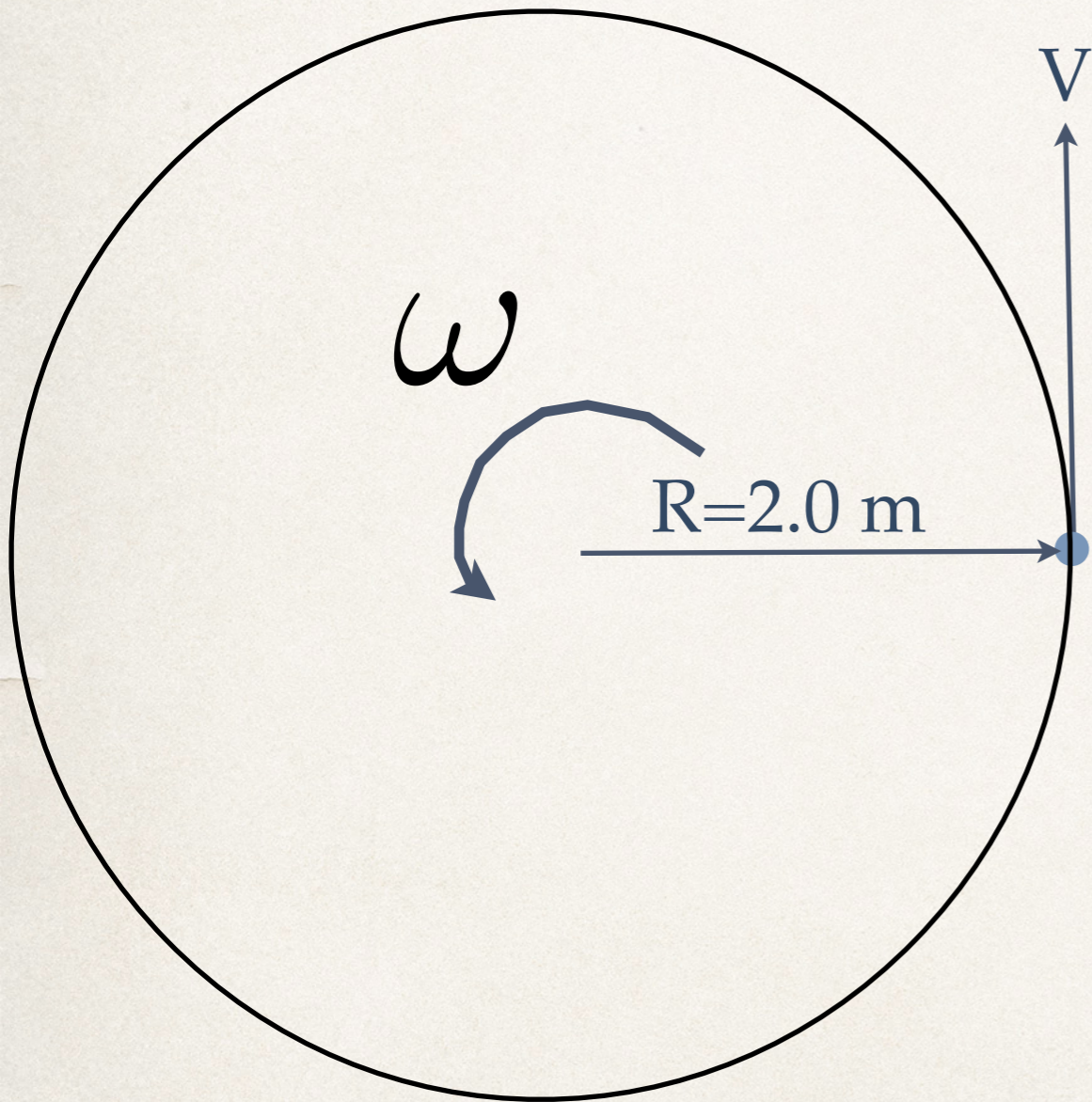

- a) increases by factor of 2
- b) remains the same
- c) decreases by factor of 2
- d) increases by factor of 4
- e) decreases by factor of 4

Suppose you can paddle your kayak at 4.0 m/s in still water. If you now enter a river flowing at 3.0 m/s, what angle, ϕ , should you point your boat to travel straight across the river?

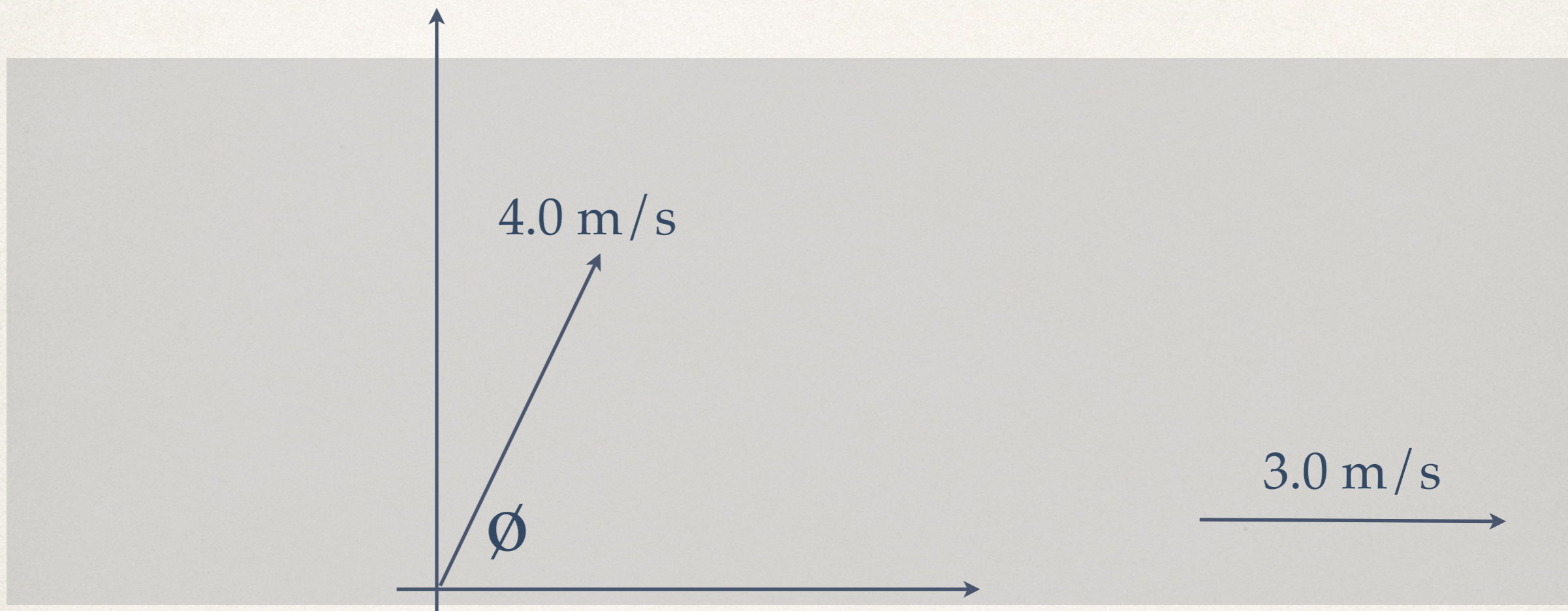

- a) 46° b) 66° c) 119° d) 126° e) 139°

For the previous question, how long would it take to cross the river? Enter your answer to the nearest second.

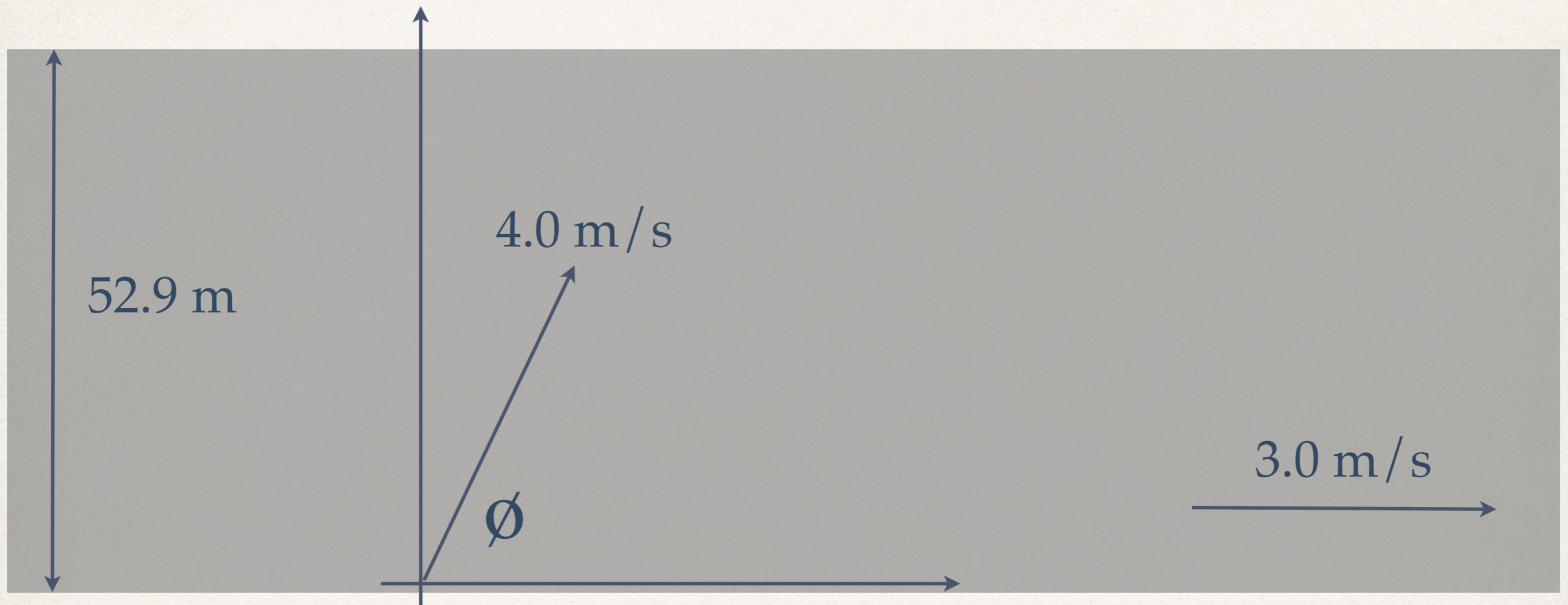

- a) 5 s b) 10 s c) 15 s d) 20 s e) 25 s

-5-

An object is lowered by a rope at a constant speed. The net force on the object is

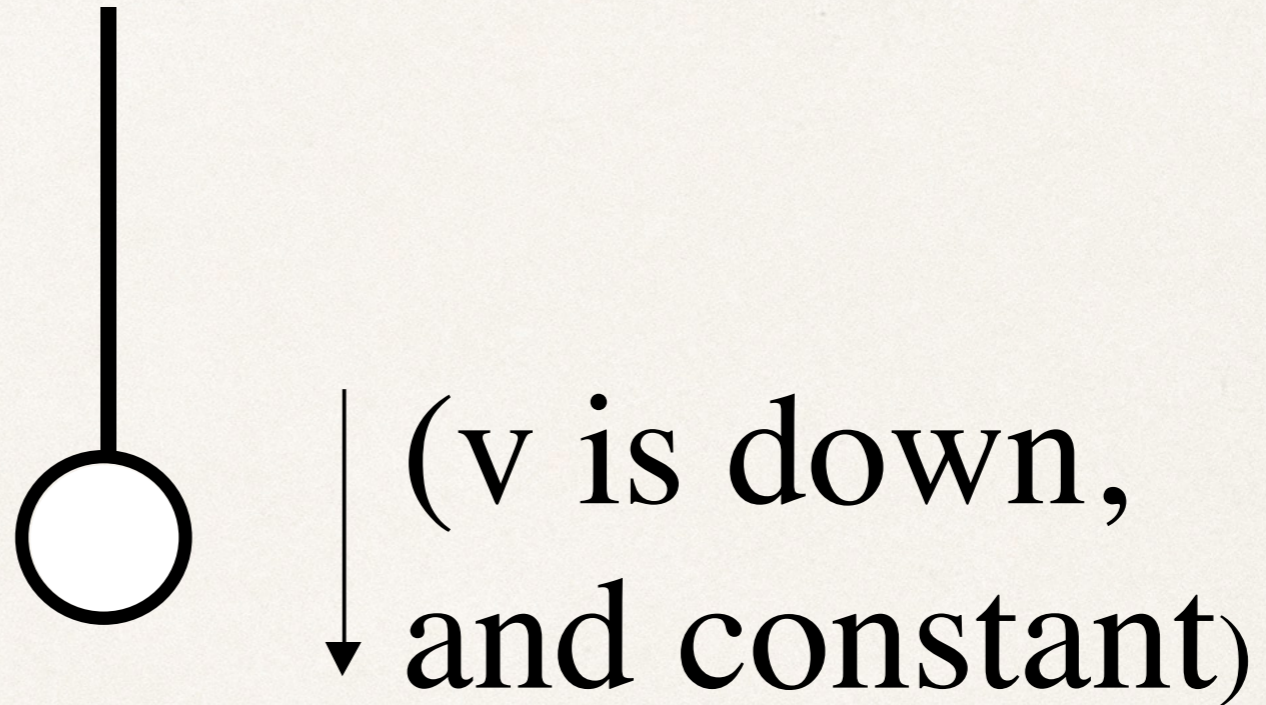

- A: upward
- B: downward
- C: zero
- D: not enough information given.

Three people are pulling on a ring in a 2-D tug of war. The figure shows a plan view of the situation.

No one is winning - the ring is sitting still.

The pulls are configured as shown (teams 1 and 2 are each pulling with a force of 100 N. Team 3 pulls with unknown force T_3)

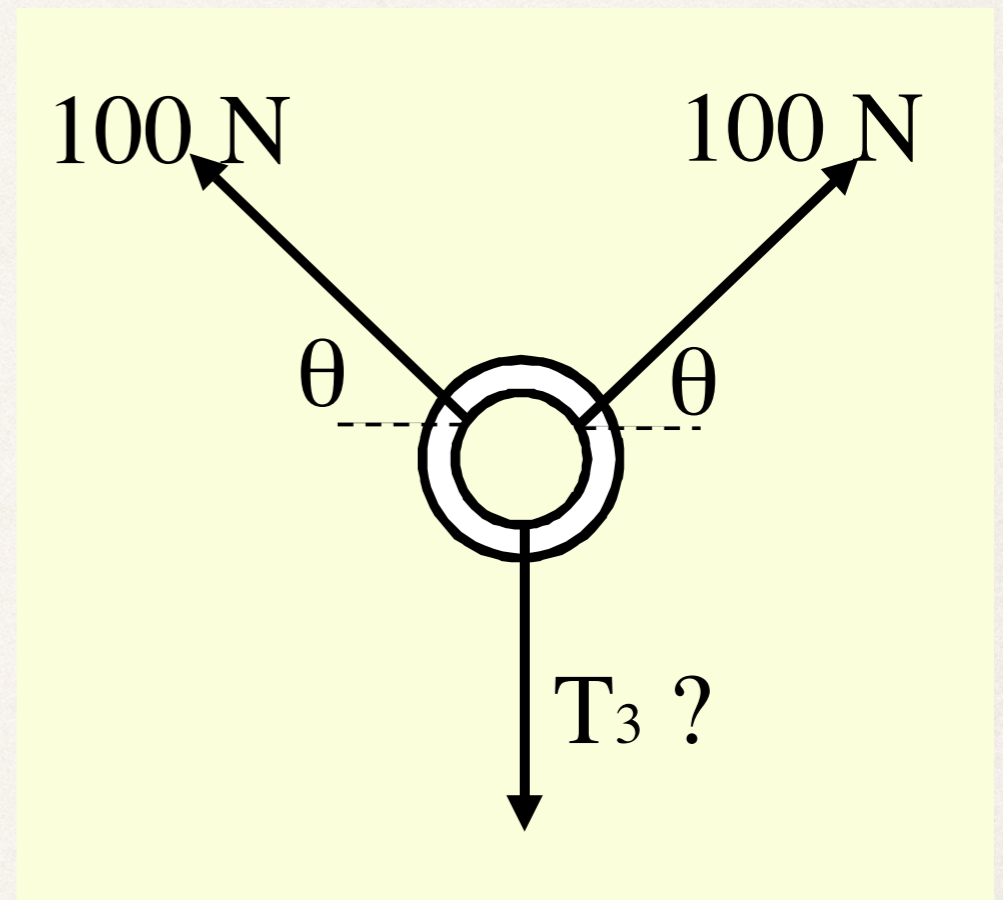

What is the net force on the ring?

- A) 0 N
- B) 200 N
- C) $200 \sin(\theta)$ N
- D) $200 \cos(\theta)$ N
- E) $100 \sin(\theta)$ N

A piano mover raises a 100-kg piano at a constant rate using the frictionless pulley system shown here. With how much force is he pulling on the rope? Ignore friction and assume $g = 10 \text{ m/s}^2$.

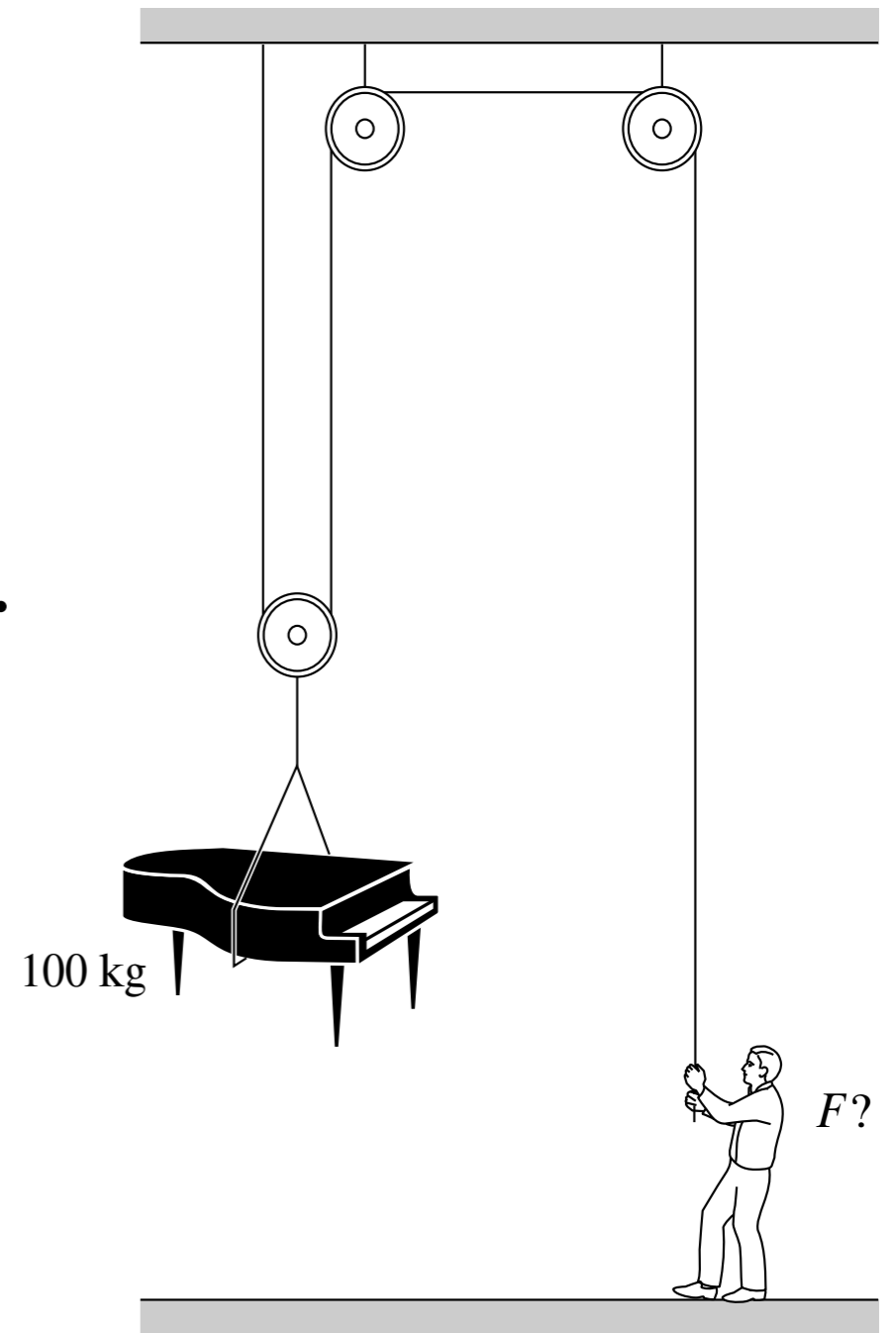

1.) 2,000 N

2.) 1,500 N

3.) 1,000 N

4.) 750 N

5.) 500 N

6.) 200 N

7.) 50 N

8.) impossible to determine

A constant force is exerted on a cart that is initially at rest on an air track. Friction between the cart and the track is negligible. The force acts for a short time interval and gives the cart a certain final speed.

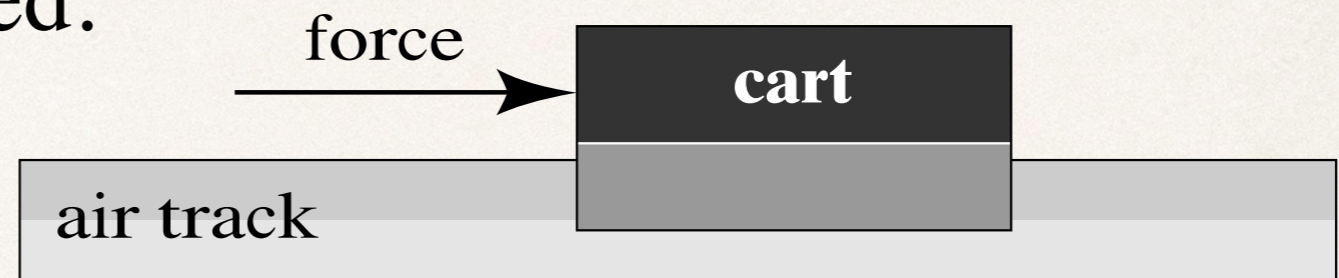

To reach the same final speed with a force that is only half as big, the force must be exerted on the cart for a time interval

- a) four times as long as
- b) twice as long as
- c) equal to
- d) half as long as
- e) a quarter of

that for the stronger force.

A constant force is exerted for a short time interval on a cart that is initially at rest on an air track. This force gives the cart a certain final speed. The same force is exerted for the same length of time on another cart, also initially at rest, that has twice the mass of the first one.

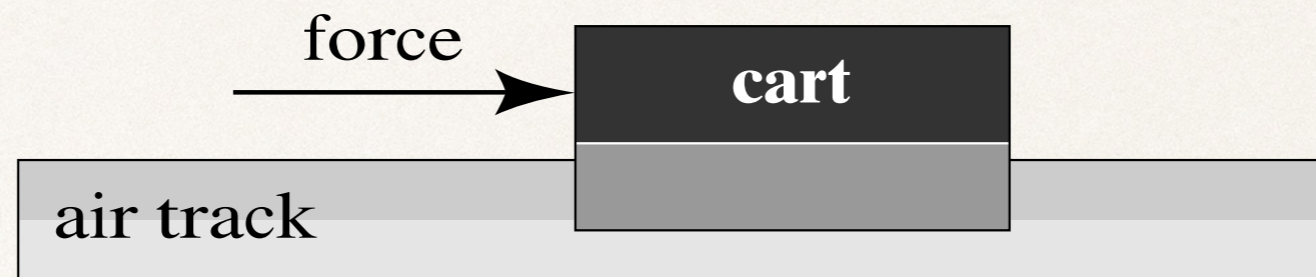

The final speed of the heavier cart is

- a) one-fourth
- b) four times
- c) half
- d) double
- e) the same as

that of the lighter cart.

Consider a person standing in an elevator that is accelerating upward. The upward normal force N exerted by the elevator floor on the person is

- a. larger than
- b. identical to
- c. smaller than

the downward weight W of the person.

An object is held in place by friction on an inclined surface. The angle of inclination is increased until the object starts moving. If the surface is kept at this angle, the object

- a. slows down.
- b. moves at uniform speed.
- c. speeds up.
- d. none of the above